

UR車輪ユニット

車輪材質 SCMn2, S45C

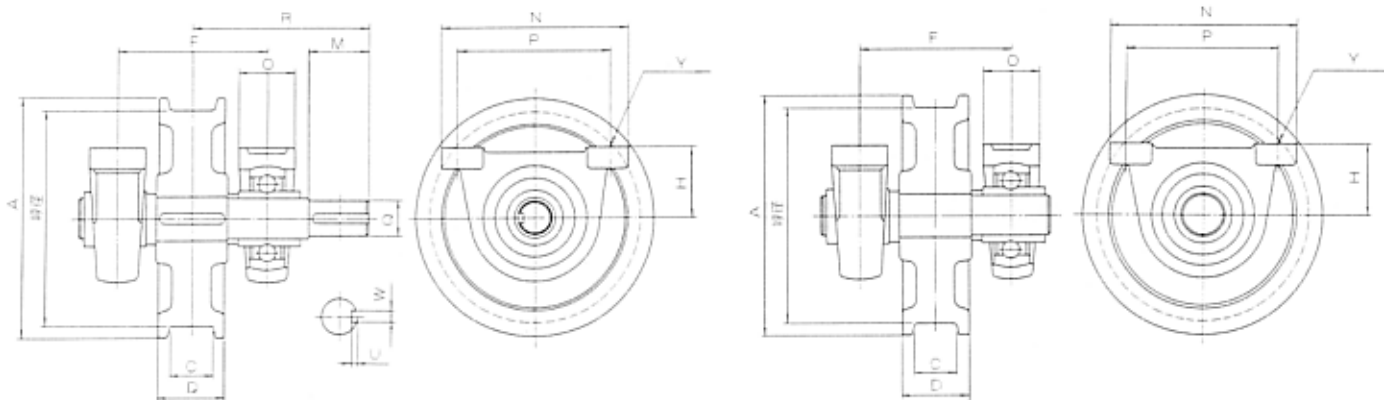

UR-A型 (車輪踏面巾C-60)

ユニットA		各 部 寸 法										軸 受 寸 法					軸受A
機 種	呼径	A	C	D	F	M	R	Q	W	U	H	N	P	O	Y	UCIP型番	
200A-1	200	230	60	90	180	63	200	40	12	5	70	220	170	60	19	210	
200A-2	200	230	60	90	180	63	200	40	12	5	80	230	180	60	19	211	
200A-3	200	230	60	90	190	63	210	45	14	5.5	80	260	200	70	22	212	
250A-1	250	280	60	90	180	63	200	45	14	5.5	80	230	180	60	19	211	
250A-2	250	280	60	90	190	63	210	50	14	5.5	80	260	200	70	22	212	
250A-3	250	280	60	90	190	63	215	50	14	5.5	110	310	250	70	22	313	
300A-1	300	330	60	90	190	63	210	50	14	5.5	80	260	200	70	22	212	
300A-2	300	330	60	90	190	80	230	55	16	6	110	310	250	70	22	313	
300A-3	300	330	60	90	195	80	235	55	16	6	110	330	270	75	25	314	
350A-1	350	380	60	95	200	63	220	50	14	5.5	110	310	250	70	22	313	
350A-2	350	380	60	95	205	80	245	55	16	6	110	330	270	75	25	314	
350A-3	350	380	60	95	215	80	250	55	16	6	120	350	290	85	25	316	
400A-1	400	430	60	100	215	80	250	55	16	6	110	330	270	75	25	314	
400A-2	400	430	60	100	225	80	260	55	16	6	120	350	290	85	25	316	
400A-3	400	430	60	100	225	80	270	60	18	7	130	400	330	85	30	318	
450A-1	450	480	60	100	225	80	260	60	18	7	120	350	290	85	25	316	
450A-2	450	480	60	100	225	90	270	65	18	7	130	370	310	85	25	317	
450A-3	450	480	60	100	225	90	270	65	18	7	130	400	330	85	30	318	
500A-1	500	540	60	100	225	90	270	70	20	7.5	120	350	290	85	25	316	
500A-2	500	540	60	100	225	90	270	70	20	7.5	130	400	330	85	30	318	
500A-3	500	540	60	100	225	90	285	70	20	7.5	150	430	360	85	30	320	

UR-B型 (車輪踏面巾C-80)

ユニットB		各 部 寸 法										軸 受 寸 法					軸受B
機 種	呼径	A	C	D	F	M	R	Q	W	U	H	N	P	O	Y	UCIP型番	
300B-1	300	330	80	120	220	63	220	45	14	5.5	80	260	200	70	22	212	
300B-2	300	330	80	120	220	63	230	50	14	5.5	110	310	250	70	22	313	
300B-3	300	330	80	120	225	80	250	55	16	6	110	330	270	75	25	314	
315B-1	315	345	80	120	230	63	230	50	14	5.5	110	310	250	70	22	313	
315B-2	315	345	80	120	235	80	260	55	16	6	110	330	270	75	25	314	
315B-3	315	345	80	120	235	80	260	60	18	7	120	340	280	75	25	315	
350B-1	350	380	80	120	230	80	260	55	16	6	110	310	250	70	22	313	
350B-2	350	380	80	120	235	80	260	60	18	7	110	330	270	75	25	314	
350B-3	350	380	80	120	250	90	280	65	18	7	120	350	290	85	25	316	
400B-1	400	430	80	125	235	80	260	60	18	7	110	330	270	75	25	314	
400B-2	400	430	80	125	250	90	280	65	18	7	120	350	290	85	25	316	
400B-3	400	430	80	125	250	90	290	70	20	7.5	130	400	330	85	30	318	
450B-1	450	480	80	125	260	90	290	65	18	7	120	350	290	85	25	316	
450B-2	450	480	80	125	260	90	300	70	20	7.5	130	400	330	85	30	318	
450B-3	450	480	80	125	260	100	320	80	22	14	150	430	360	85	30	320	
500B-1	500	530	80	125	260	90	300	70	20	7.5	130	400	330	85	30	318	
500B-2	500	530	80	125	260	100	320	80	22	14	150	430	360	85	30	320	
500B-3	500	530	80	125	280	112	350	90	25	14	170	490	410	100	33	322	
560B-1	560	600	80	125	260	90	320	70	20	7.5	150	430	360	85	30	320	
560B-2	560	600	80	125	280	100	340	80	22	14	170	490	410	100	33	322	
560B-3	560	600	80	125	280	112	350	90	25	14	170	510	430	100	33	324	

車輪踏面硬度 HS 26以上

焼入車輪踏面硬度 HS 50±5